

# Sub-Retinal Implants Based on CMOS Chip With Active Pixel Array

## Introduction

Some people suffer from blindness due to an evolving loss of photoreceptor cells. One reason for the degeneration of rods and cones can be the hereditary disease retinitis pigmentosa. Here, the retinal network, consisting of optic nerve, ganglion and bipolar cells, remains intact. Hence, an artificial substitution of the photoreceptor cells might restore vision for the blind.

The retinal implants under consideration are sub-retinal implants. This means they are positioned beneath the retina as illustrated in Fig. 1. A two-dimensional array of photodiodes and electrodes, positioned on the same side of a microchip [1][2], serves as the required light-to-current converter that can stimulate the bipolar cells. The microchip additionally provides amplification circuitry. As the sub-retinal implant resumes the same place as the degenerated photoreceptor cells, the remaining retinal network is directly employed for natural signal processing.

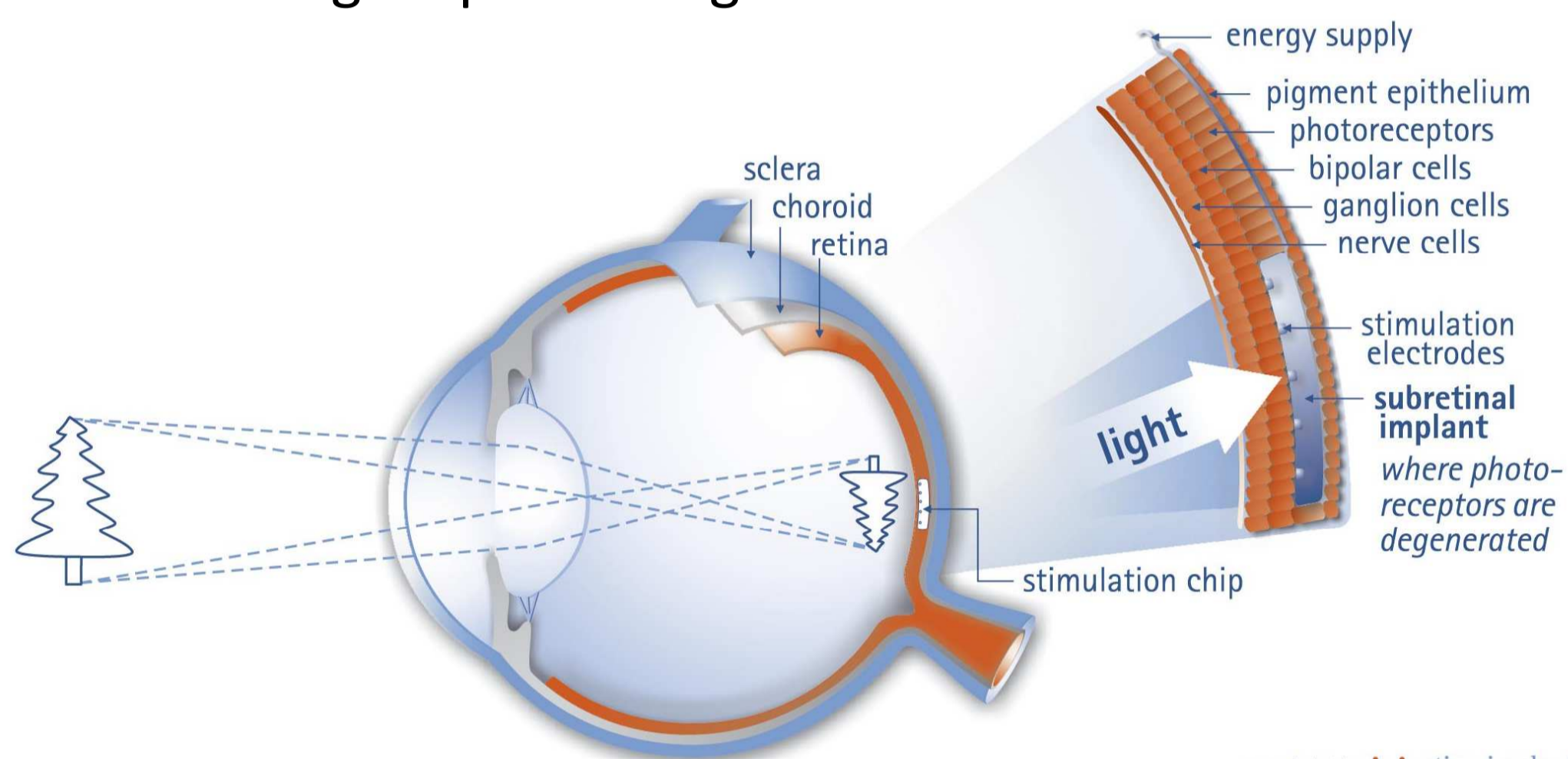

Fig. 1: Cross section of the retina and position of the sub-retinal implant.

## Functional Principle of Sub-Retinal Implant

The retinal chip (Fig. 2, A) has a size of about 3x3 mm<sup>2</sup>. This allows for a viewing angle of approximately 15° [3]. The chip is mounted on a flexible foil substrate (B). These are the two components of the intra-ocular part. The chip is placed during the implantation beneath the fovea [4]. A picture of the implanted chip inside the human eye is depicted in Fig. 3. The foil leaves the eye via a scleral flap and is fixed to the sclera with the help of a patch (C). To receive energy and control signals, the chip is connected via a subcutaneous cable (D) to a supply unit (E) that is

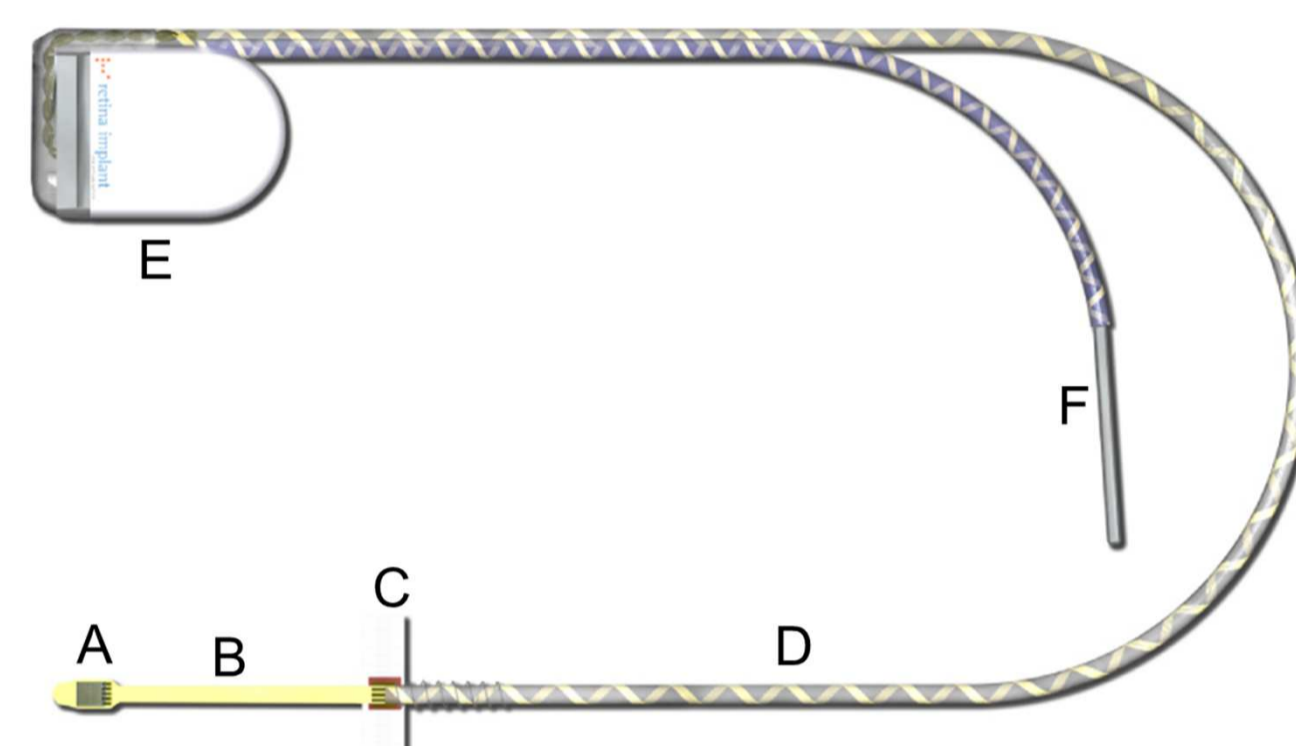

Fig. 2: Retinal Implant Alpha IMS.

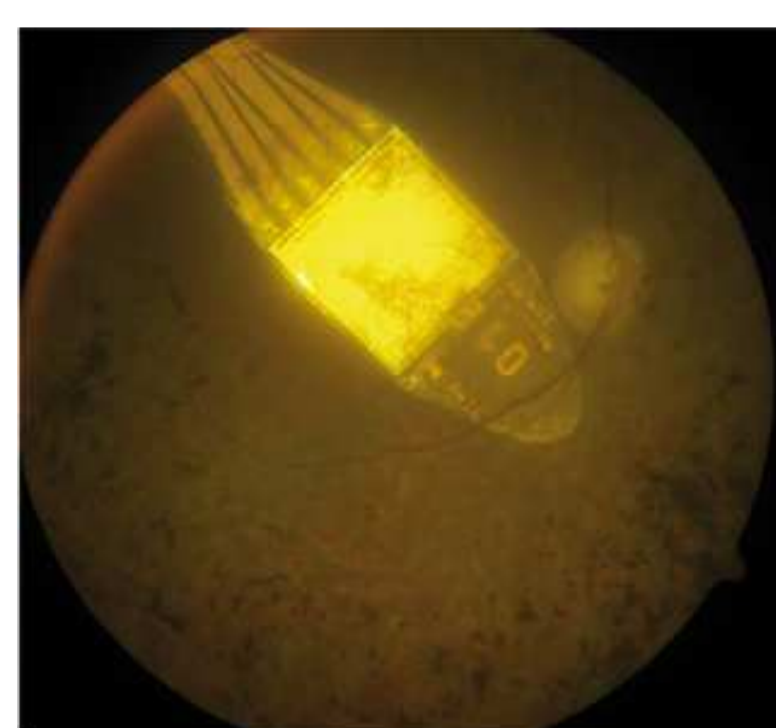

Fig. 3: Fundus view of the sub-retinal implant in the human eye [3].

positioned behind the ear of the patient. The internal supply unit contains a coil for inductive coupling to the external supply unit. The latter one is shown in Fig. 4. It enables the user to adjust two parameters, namely Gain and Sensitivity. The whole device is battery driven. A counter electrode (F) collects the charge that is transferred from the chip electrodes. The counter electrode is connected to the retinal chip ground to close the current path. In Fig. 5, the typical transfer characteristic of a sub-retinal implant Alpha IMS in dependence of Gain and Sensitivity is illustrated [5].



Fig. 4: External power supply with rotary knobs to adjust Gain and Sensitivity.

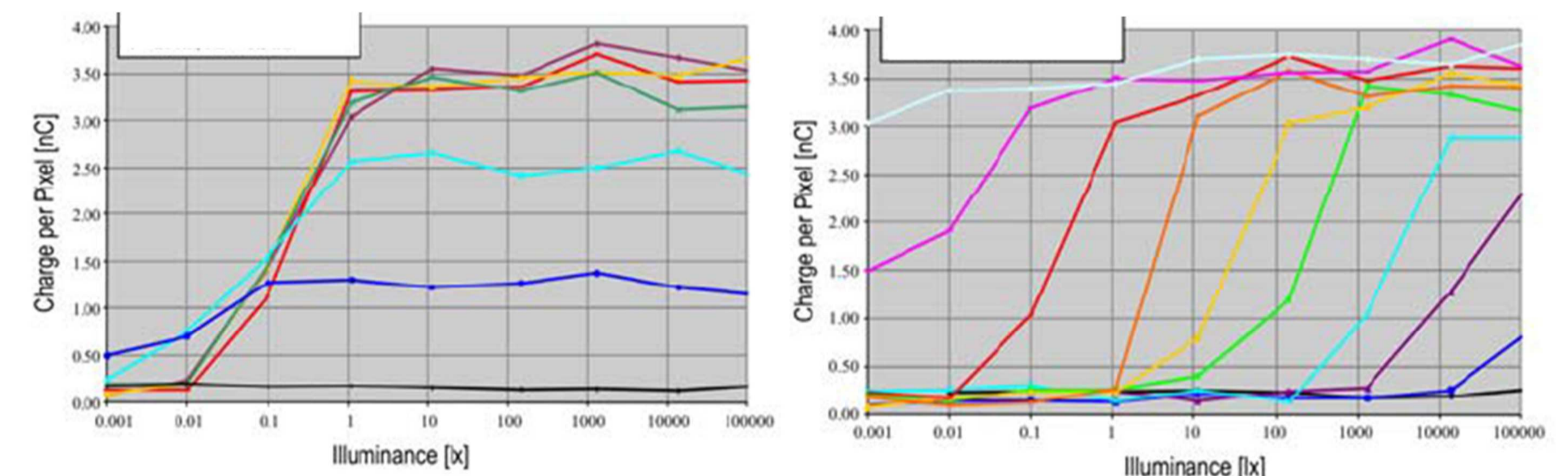



Fig. 5: Transfer characteristic of a sub-retinal implant in dependence of Gain (left) and Sensitivity (right) [5].

## Technical Specifications of IMS and AMS Chip

Technical Specifications	Chip Comparison	
	Alpha IMS	Alpha AMS
Technology	0.8 μm p-well CMOS	0.35 μm Opto-CMOS
Design	ims-chips Stuttgart, Germany	Institute of Microelectronics, University of Ulm Ulm, Germany
Fab	ims-chips Stuttgart, Germany	ams AG Unterpremstaetten, Austria
Opto Options	no official data available	Anit-Reflective Coating (ARC), EPI-layer
Stimulation Signal	monophasic anodic pulse 	biphasic pulse, cathodic first 
Supply Voltage	DC	AC
Control Signals	voltage	current
Pixel Number	1500	1600
Pixel Patterns	1	4
Testing	Pad frame that has to be sawn off	Integrated test patterns

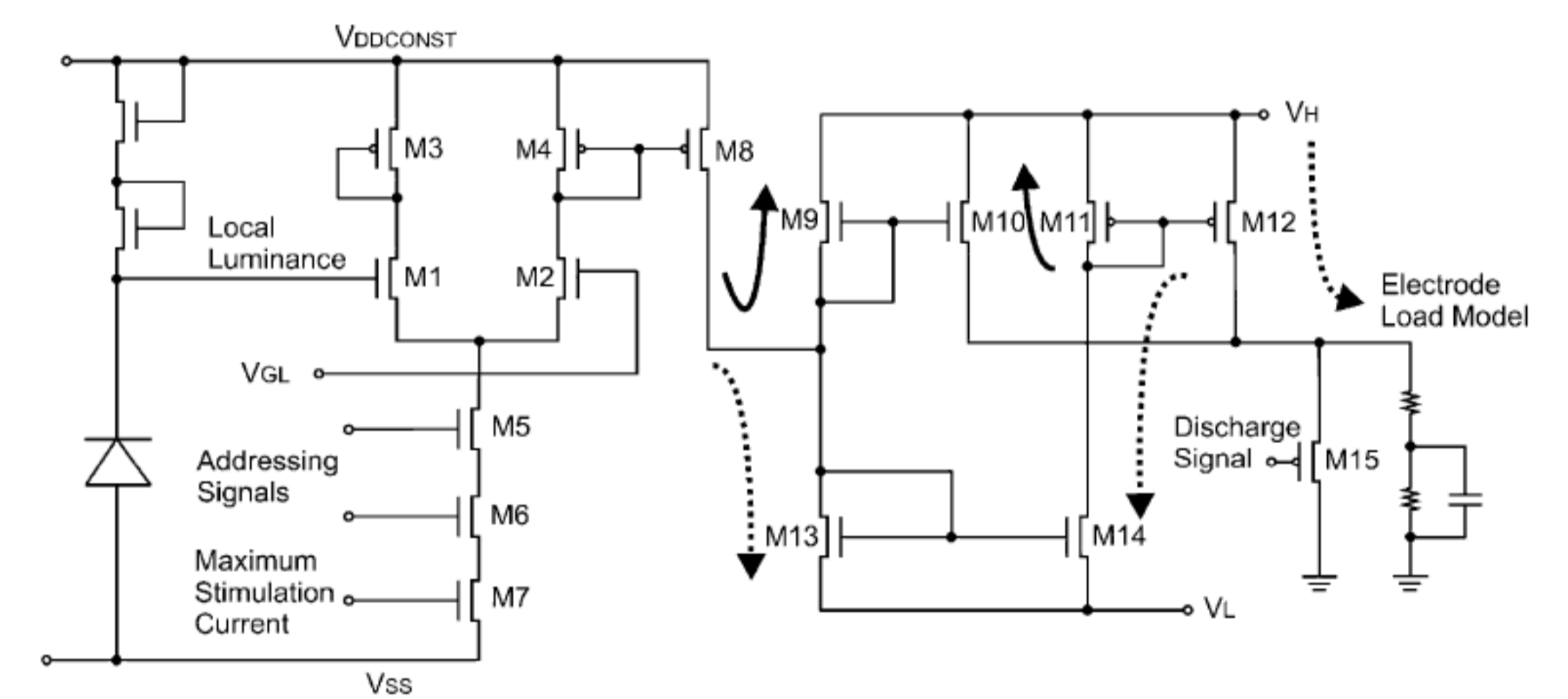
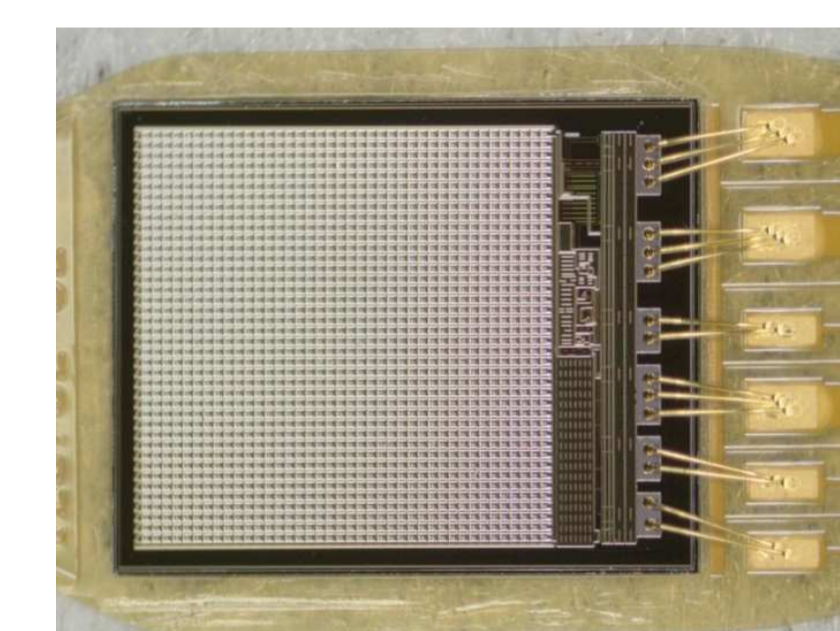
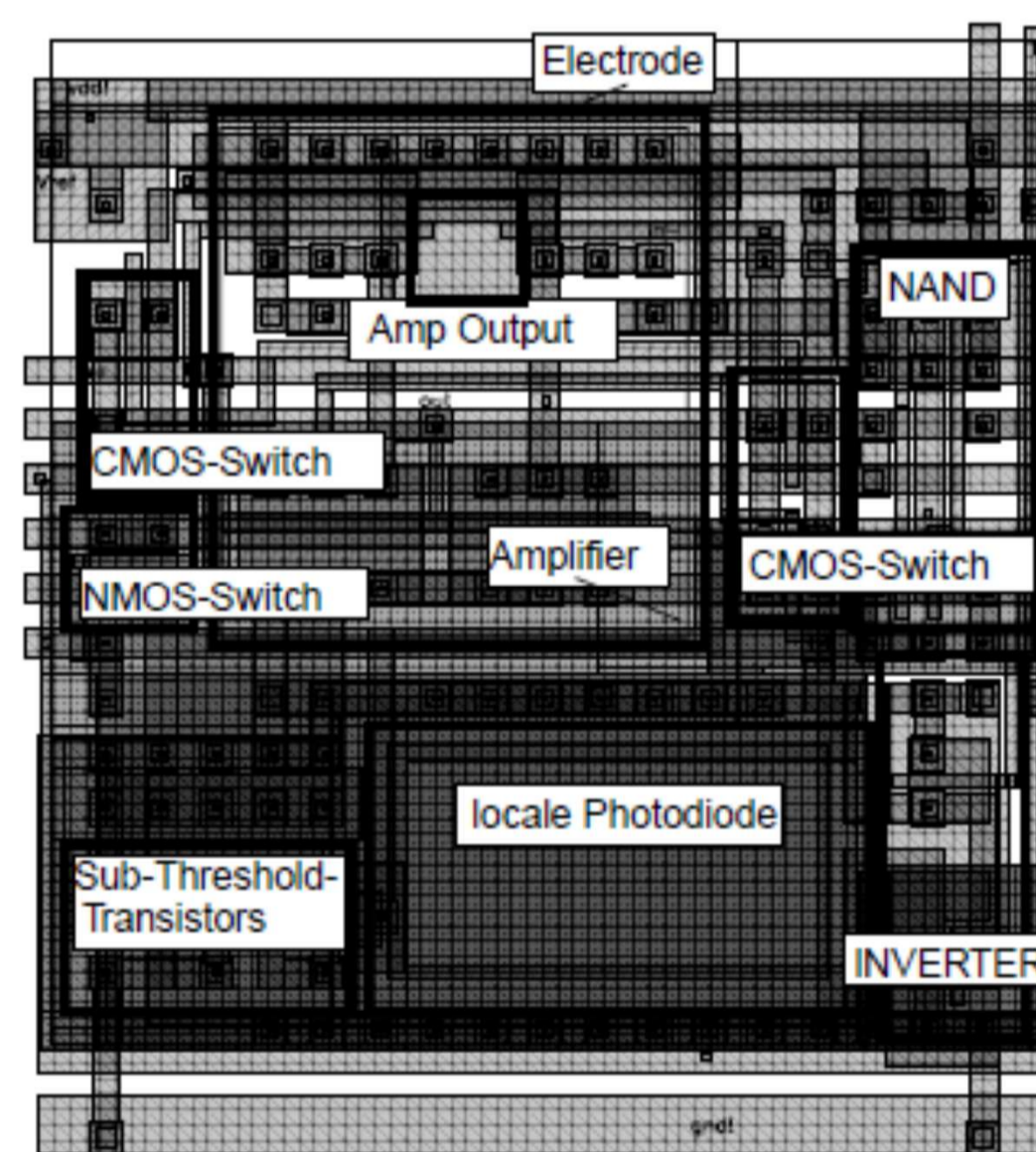
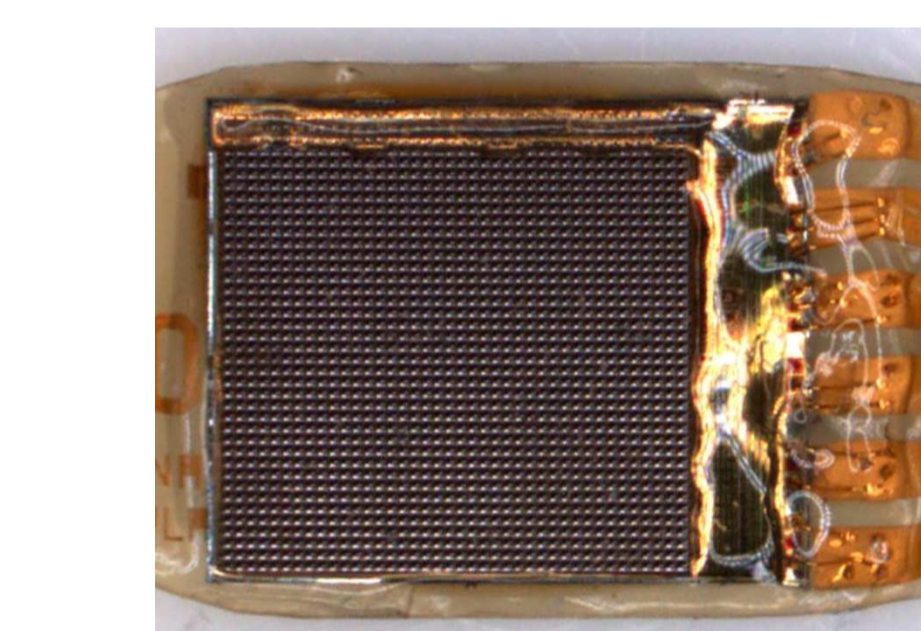

Fig. 6: IMS Chip (left) and AMS Chip (right): Photograph of chip on foil substrate (top) and overview of pixel cell (bottom) [1][2].

## Clinical Results of Alpha IMS

It could be shown [4] that at least two-thirds of the 8 blind patients, who have participated in the single-center study with the Alpha IMS retinal implant, regained useful vision in daily life. Here, the stimulation frequency is usually set to about 5 Hz.

The test results with the projector-screen set-up as displayed in Fig. 7 can be summarized as follows: All participating patients had light perception. The majority could locate the light source and detect motion. For three quarters of the patients, grating acuity measurements were possible, and for one quarter, visual acuity measurements. One patient achieved a visual acuity of 0.04, which is above the value that defines blindness according to German law (0.02).

Half of the patients could recognize large letters, and the majority found the visual experiences with the implant useful in their daily life. The patients describe the vision with the implant as similar to "an older black-and-white television set" [4].



Fig. 7: Screen tests applied during clinical studies [4]: Light perception threshold, light source localization, motion detection, grating acuity, visual acuity.

## References

- [1] A. Dollberg et al., „A Fully Testable Retinal Implant“, Proceedings for the IASTED International Conference Biomedical Engineering, June 25-27, 2003, Salzburg, Austria.
- [2] A. Rothermel et al., „A CMOS Chip With Active Pixel Array and Specific Test Features for Subretinal Implantation,“ IEEE Journal of Solid-State Circuits, Vol. 44, No.1, pp. 290-299, January 2009.
- [3] K. Stingl et al., „Safety and efficacy of subretinal visual implants in humans: methodological aspects“, Clinical and Experimental Optometry, August 2012.
- [4] K. Stingl et al., „Artificial vision with wirelessly powered subretinal electronic implant alpha-IMS“, Proceedings of the Royal Society B 2013 280, 20130077, February 2013.
- [5] E. Zrenner et al., „Details on the Technology of the Subretinal Implant, Clinical Study Design, Results and Spontaneous Reports of Patients including nine Movie Clips on performance“, Proceedings of the Royal Society B, October 2010.